

# On the Paternity and Legitimacy of Children in an Agnatic Society: A Case from the Banna of Southern Ethiopia

KEN MASUDA

*Kanagawa University*

---

This paper sets out to examine the paradox of matrilineal aspects among patrilineal societies in Africa, which was famously pointed out in the Nuer ethnography by E. E. Evans-Pritchard, and focuses on gender and sexual aspects of the indigenous theory of kinship among the Banna of southern Ethiopia. For this purpose, I describe some local strategies for securing descendants and children's legitimacy. It follows that the concept of paternity must be analyzed by investigating the rules of marriage, sexuality, and the role of the *baski*, a term which could be translated 'lover' or 'levir' and denotes a man who lives with a widow in a relationship similar to marriage but not recognized as such. Paternity has ideological aspects which prescribe the legitimacy of children: in the case of the *baski*, he cannot give legitimacy to his lover's children even though he is their biological father. Therefore we must distinguish paternity from two perspectives: (1) whether the father is a pater or genitor for the children, and (2) whether he is a legal or illegal marital partner for the children's mother. This is a sort of local knowledge of reproduction technology: the Banna vary their interpretation of sperm and ovum, acquiring their descendants through a process of social manipulation.

**Key words:** Banna, Omotic, gender, sexuality, kinship study.

---

## 1. INTRODUCTION: EVANS-PRITCHARD THESIS

Gender and sexuality have become one of the most challenging issues for anthropologists describing other societies. It has become a common assumption that the distinction between male and female is socially constructed. Men and women are not simply defined as biological male and female. The long tradition of kinship studies within anthropological discourse has been challenged to deconstruct its unconditional premise in favor of "constructing systems" for each particular society.

After a detailed description of Nuer marriage customs, Evans-Pritchard concludes: "Hence it follows that agnatic descent is, by a kind of paradox, traced through the mother, for the rule is that in virtue of payment of bridewealth all who are born of her womb are children of her husband and therefore paternal kin, by whomever they may have been begotten" (Evans-Pritchard 1951: 122). Needless to say, all agnatic (or paternal) societies are not like this. As Matsuzono (1987) describes in an Okinawa case, it is quite easy to find societies where the matter of "by whom they have been begotten" appears to be significant<sup>(1)</sup>.

The people of Hamar, the neighboring people of the Banna<sup>(2)</sup>, have the same idea of paternity as the Nuer. "In Hamar, it doesn't matter who the natural father is of a woman's

child, her husband is always the official father. This means that if a woman doesn't get pregnant by her husband she can try to get pregnant by someone else, and even after her husband is dead she can carry on bearing children who are said to be his" (Lydall 1994: 217).

While we are easily able to confirm the Evans-Pritchard thesis in this case, here remain some problems to be solved. For example, a physical connection between father and child is not readily apparent, whereas that between mother and child cannot be concealed according to the fact of her delivery. As Barnes pointed out (Barnes 1973: 68), recognition of genitor is not even a purely biological matter, but rather is socially prescribed. This asymmetry seen between paternity and maternity (Strathern 1992: 26) precludes analysis of both father-child and mother-child connections from a single perspective. Hutchinson, in an article analyzing gender and sexuality on the basis of Evans-Pritchard's ethnographic data, argues on motherhood and fatherhood that while physical and social maternity are inseparable in the eyes of the Nuer, the reproductive power of men, in contrast, is not innate but rather communal. "Procreative power of a man is merged with that of his agnatic kinsmen through the ancestral herd. Corporate solidarity and continuity are founded upon this principle of 'communal fertility' through cattle" (Hutchinson 1980: 376).

On the one hand, female identity points toward the future, meanwhile the mother-child unit is not permanent but lasts only for a generation because this unit is exclusive and founded upon the innate connection between them. On the other hand, male identity, established by collectivity and ideology, is of permanence. It is passed down from generation to generation and points to the past. Each time vector seems completely opposite. Asymmetrical relations between paternity and maternity should be seen from this perspective. Therefore, marriage among the Nuer, and perhaps the Banna too, can be grasped as a bridge which joins the past (from ancestors) with the future (to descendant), and gender and sexuality appear to be important issues in social life.

This article focuses on the gender and sexual aspects of the Banna's indigenous theory of kinship from both the ideological and practical side.

## 2. SEXUALITY AND MARRIAGE

### 2.1. Youth, Engagement, and Pregnancy

In Banna, the virginity of a girl is not viewed as a significant issue at the time of her engagement. I am impressed that the attitude to premarital sex is so generous. We may assume that young people have plenty of experience of sexual intercourse.

Boys seem to start to have sexual experiences around the age of fifteen after having their foreskin cut.<sup>(3)</sup> Girls may have sex after they undergo a ritual held by a ritual master (*gudul*) when they have their first menstruation.<sup>(4)</sup> Some describe the moment as "getting her breast swelling".

It is said that boys and girls get the opportunity to have sexual relations at dance gatherings (*warsa*) at night. Lovers make plans during dancing to meet in the bush. A young man sometimes has several girl friends, and likewise, a girl is not restricted to having only one boy friend.

There are over twenty clans in Banna society, each of which is classified as being in either the Binnas moiety or the Galabu moiety.<sup>(5)</sup> One cannot choose his/her spouse from the same clan or any other clan in the same moiety: for example, a youth of the Gata clan, which is in the Binnas moiety, must marry a girl from any clan of the Galabu moiety. Of course they never marry their first paternal cousin because of common clanship, but neither do they marry their first maternal cousin even though they are members of a different clan. Moreover, people tend to avoid engagement between lineages that have memories of marriages in the recent past.

Someone who satisfies these conditions will be in the marriageable category which is called *tsangaza* or *tsangazi*. The unmarriageable category is named *eda*.<sup>(6)</sup>

Payment of bridewealth is necessary for marriage to happen. In some cases lovers try to elope. An elopement may be done as a demonstration of their strong will to marry, and in the end they are usually permitted to be engaged unless the case violates the *tsangaza/eda* rule.

In the elopement version of marriage, every step related to normal marriage (negotiation, payment of bridewealth etc.) must be done in just the same way.<sup>(7)</sup>

It usually takes several years after establishing the engagement for the newly married couple to begin their new life. A bridegroom is required to undergo another ritual to take his wife to their new house which, in most cases, stands near or inside his father's household. The bride (called *uta*) is painted in red ochre and butter and has her hair shaved.

The couple cannot have sexual relations in the first three or four months. During this period, the bride, who is still painted in red ochre and butter, does not work and must stay in the house with a kinswoman (ideally an old woman) who is responsible for making sure that the bride has her menstruation (*doobi*, which means "rain") every month. If she misses her period, then unless the couple married after the pregnancy became evident, that is taken to mean that she is carrying a baby begotten by a man other than her own husband. In that case, people strongly suggest that the only decision they can make is abortion or infanticide<sup>(8)</sup> to avoid fostering another man's biological child as their legitimate offspring. Since pregnancy, in this case, happens before the bride starts to live with her husband, she does not have to be punished.<sup>(9)</sup> Here it can be seen that the Banna recognize the causal relation between pregnancy and menstruation (i.e. when she is pregnant, she does not have her period).

A woman may bear one child every three years, since husband and wife do not have sexual relations for at least two years after the birth of the previous child. They have to undergo the *boDi* ritual carried out by an old woman in order to start having sexual relations again. The wife also has to undergo the *boDi* ritual whenever she has her period. Ideally this takes seven days to complete. They conduct the ritual at the dumping ground behind the house in the early morning. On the first morning, the wife sips water once from a gourd bowl served by the old woman, then throws away the rest of the water in the bowl. She has two sips on the second morning, three sips on the third morning, and so on, until she has sipped water seven times on the seventh morning, after which the two women trample and break the bowl.

The *boDi* ritual is a necessary step toward bearing a legitimate child because the child would be *ubasa* if the baby was begotten without completing the seven-day ritual. If a woman has sexual relations with her husband and bears a child without any *boDi* procedure, the baby would be called *duba*. In the past both *ubasa* and *duba*<sup>(10)</sup> children were aborted or killed as soon after birth as possible, but nowadays an *ubasa* baby can be kept alive after ritual purification by the chief (*bita*).

A new bride finishes putting on red ochre and butter and shaving her hair when she is attested to have menstruation as proof that she is not pregnant and therefore ready to bear. She is now able to let her hair grow and begins to put red ochre and butter on her braided hair, not on her body. It is easy to distinguish a married woman from an unmarried woman by focusing on her hairstyle. In the Banna language, the word *anza* means unmarried women only when it is contrasted to the word *maa* (married women), while *anza* generally indicates the whole category of female.

## 2.2. Double Standards on Sexuality

Since a new bride does not live with her husband until he has finished some percentage of his bridewealth payment, it is possible for her to continue to have sexual relations with her former boyfriend(s) between the engagement and officially commencing married life. However, as soon as agreed percentage has been paid and the final ritual of marriage has been held, she becomes subject to the standard prohibition of adultery. It becomes impossible to behave as before marriage. It is considered inevitable that a married woman who has an adulterous relationship will be injured or even killed by her husband. Indeed, I witnessed a case in which a husband, whose wife had slept with another man, chased her with a rifle.

I would like to present a similar case which happened to the lineage of the chief of the western Banna at the beginning of this century. The then chief Dore Wangi was arrested on unconfirmed suspicion and taken to a prison in Addis Ababa. During his absence, most of his wives (said to have numbered fifteen) took lovers and bore children. When Dore came back to Banna, the wives and lovers ran away, afraid of being killed by him.

It is therefore apparent that there is a double standards in sexuality between male and female. On the one hand a man's marital status never limits his ability to have sexual relations unless his lover is other man's wife. On the other hand a married woman is forbidden from having extra-marital relations. Lydall discusses the double standards, in her article on wife beating, where she mentions that, in Hamar, a husband can "reasonably" beat his wife for the reason that she does not work hard enough as a housewife. Lydall asked one of her Hamar informants; "Now, perhaps your husband won't herd the livestock well, will you then beat him?" The answer was of course "No". The informant said, "With us Hamar, if a woman beats a male, she'll be killed, she the wife". Lydall adds, "I knew that if a man kills his wife, for whatever reason, neither her family nor the local community have the right to retaliate or demand compensation" (Lydall 1994: 223).

### 3. LEGITIMACY OF CHILDREN

It is prohibited for an unmarried woman to bear children, despite the strong possibility of pregnancy in young girls stemming from their frequent sexual relations. If a pregnancy occurs, they will choose one of two ways out: abortion or infanticide.

The questions, "Why do you [the Banna] choose such ways?" and "Why don't you let the baby live" led to these answers: "If we let the baby live, who could be its legal father?" or "Who on earth would foster it?"

These answers suggest that there would not be an amicable settlement even if someone adopted and fostered the child. This point suggests that children's legitimacy is assured only through satisfying several conditions. The Banna cannot imagine the existence of a "socially illegitimate child" nor an "unmarried mother".

The problem of premarital pregnancy is solved in two ways which appear to be opposed, i.e. abortion/infanticide, or urgent marriage. On the one hand, abortion and infanticide are based on the idea that children who do not have legitimacy should not be born. On the other hand, urgent marriage is carried out to create legitimacy for the children. Hence we can say that the vital concept in solving the problem of premarital pregnancy is legitimacy.<sup>(11)</sup>

If an unmarried girl becomes pregnant and the fetus' biological father is apparent, they can urgently marry only provided that the man has already undergone initiation and satisfies other conditions (combination of clans, bridewealth and so on). Thus the child's legitimacy would be ensured by establishing a legally sanctioned father (pater) would ensure. Banna men are required to have undergone an initiation ritual (*atsa*) preceding marriage, so that initiation is an absolute prerequisite for urgent engagement caused by premarital pregnancy. In such cases, however, the ritual itself must be simplified because of the lack of preparation.

The Banna have several ways of inducing an abortion: for example, (1) using modern medicine like tetracycline, malaria medicine, tsetse medicine (properly for cattle), (2) using traditional medicine in which honey and an indigenous herb are mixed, and (3) finger pressure therapy by someone who has knowledge of particular points around the temple and the navel which are effective in discharging the fetus. The man who impregnated the woman, must pay for the cost of the abortion treatment.<sup>(12)</sup>

If it is too late to have an abortion when the premarital pregnancy comes to light, the Banna resort to infanticide. I was informed of three ways of killing baby: (1) leaving the baby in the bush, (2) burying it alive, and (3) suffocation by strangulation or pressing something against the face.<sup>(13)</sup>

The top priority for a newly married couple is to beget a son.<sup>(14)</sup> The first-born son of the first wife is called *jallafa*<sup>(15)</sup>, and is designated as the father's sole successor and the distributor of his property. It is very problematic for a couple not to have any son, even if they have many daughters. In a serious case, where a man dies without a *jallafa*, the man will be called *eedi haymaya*.

The disgrace of being *eedi haymaya* can be seen in the style of burial. There are generally three modes of burial. Firstly, the general way, called *yekede dooki*, is for a stony mound about one meter high to be made above the ground in which the body is buried. This is for married men and married women. The second is the way for unmarried people, and here the body

is buried in a hole dug in the pile of cow dung (*duba*, referred to above) in the cattle kraal. The third way is for *eedi haymaya*. The body of the *eedi haymaya* is buried in the bush, neither in the cattle kraal nor in the village, without a stony mound to identify the location. No property of his must be left in or around the village. All the livestock may be consumed, and his house, his rifle and other property will be burnt, for avoiding that he becomes a *meshi* (an evil ghost which is thought to bring disaster to the human world). Everything showing his individuality should be erased.

The need to avoid this fate by establishing a legitimate heir explains the importance of the *jallafa*, who must be a legitimate son, i.e. born to a "legal wife".

#### 4. BASKI

##### 4.1. The widow's choice

Divorce, which leads to the refund of bridewealth, is basically only possible in the case of wives lower in rank than the first wife is. The first wife cannot be divorced for any reason. However, I do not have any examples of divorce among the Banna, reflecting the rarity of the practice. We can form two hypotheses for this low rate of divorce: (1) a husband needs a labor force in his household, (2) he may marry another woman if his wife cannot beget a child.

Divorce can happen because of the wife's infertility. However, as Jensen notes, if the wife's infertility becomes apparent during the period of payment of the bridewealth, the husband would continue to pay it because she is useful as labor in the household. In such a case, the husband can ask his wife's father to arrange his next marriage for a lower price (Jensen 1959: 332).

Widows are prohibited from marrying again after their husband's death. However because of the difficulty for a woman to live alone in this society, most widows are driven to find some way of cohabiting with a man out of necessity. One of the most popular ways is to choose a married man as a *baski* and live with him in a marriage-like relationship. Thus a widow can acquire both her sexual partner and patronage. A widow also has the choice of living with her son if he is already grown up and has his own family. In general, old women choose this way even if their husbands are still alive.

A widow will be liberated from the prohibition against extra-marital relationships after three years of mourning, and then she becomes able to enjoy her own life as when she was unmarried<sup>(16)</sup>. Sometimes a widow enters into quasi-marriage with her *baski* after the three years' mourning period. A younger brother<sup>(17)</sup> of the deceased husband is expected to take the role of *baski*. Unmarried men can be *baski* only if they have undergone initiation and have already made their own engagement. However these rules are not strictly enforced. In this sense, *baski* rule is not a so-called levirate.

Nevertheless, it is worthwhile considering the relation between *baski* and widow with regard to leviratic relations in an anthropological context. Potash points out three characteristics of a leviratic relationship, (1) widows are usually inherited by a husband's kinsmen (although non-kinsmen and maternal nephews may sometimes be levirs with the permission of the kin group); (2) the relationships are socially recognized as legitimate; and (3) children are considered to be the descendants of the deceased and not the levir (Potash 1986: 7). From all these viewpoints, there are similarities between *baski* and levir.<sup>(18)</sup>

On the one hand, being a *baski* seems to be one of the favorite things for Banna men. On the other hand, for women, although it is very important to choose a *baski* from the economic point of view, affection is likely to be the decisive factor. Men are said to prefer living with their mistresses rather than their proper wives because of the affection between men and mistresses. Thus a lot of men want to be *baski*. I have no doubt that a man other than a younger brother of the dead husband sometimes becomes a *baski* as a result of a choice depending on affection.

Focusing on affection, we can recognize that the *baski* relationship is not only leviratic but also includes aspects of concubinage.<sup>(19)</sup> Goody, comparing leviratic relations to widow concubinage among the Nuer, points out that these two relationships are based on the same

principle, i.e. the child's legitimacy belongs to his/her social father, i.e. the man who paid the bridewealth (Goody 1976: 43). In the Banna's case, we can see both leviratic and concubinage aspects in *baski* relationships.

While a *baski* is recognized as different from a legal husband, the combination of the *baski* and his mistress (the widow) usually functions as a household in actual life. For example, in Figure 1, people in the Bori village stated that Aike was a son of Darte. This can be explained in that Darte plays the role of father in everyday life, even though people know that Aike's legal father (pater) is Banki, not Darte. Aike also introduced Darte as his "father" (*imba*) to me at the very beginning of my research.<sup>(20)</sup>

Children born between a widow and her *baski* are regarded as offspring of the deceased father. Nowadays in Banna, an individual's "full name" consists of his/her proper name and the social father's name. The name of the mother's *baski* cannot be used. Thus Aike's full name must be Aike Banki.<sup>(21)</sup> However, the *baski* seems to behave paternalistically like a "real father" in daily life, and can be temporarily in charge of property of the deceased husband of his mistress. The widow can also administer her husband's property until her son is old enough to do such work.

4.2. The *Baski* Household

This section intends to show, by reference to Figure 1, one case of a *baski* household I saw in the Bori village in 1993-94.<sup>(22)</sup>

When he died, Aike's father, Banki, seemed to be around 40 years old. This was around 1970 (in the Gregorian calendar). He had two wives, Sopa and Wale. Sopa had born two children and Wale had born one child before Banki passed away. During my first research period in 1993-94, Sopa took Gele as her *baski*. Gele was the son of Kotsa, who was the younger brother of Banki's father Garsho. Gele can be called a younger brother of Banki in Banna kinship terminology. Wale took Darte as her *baski*. He was the son of Banki's father's younger brother, and thus also Banki's "younger brother". Wale bore four children, among whom only Aike was Banki's biological son, and the other three were Darte's biological children. Children whose biological father is their mother's *baski*, are sometimes called *baskamo naasi* (*baski*'s child), but this kind of distinction is not noted in daily life.

The dwelling of a polygamous family generally takes the form of a compound in which live one man (the head of the family) and his wives and children. It has a cattle kraal, a goat kraal and land for cultivation.<sup>(23)</sup> The family's land is usually surrounded by a fence, and includes one main house for the first wife in which all the members of the family carry out chores, greet

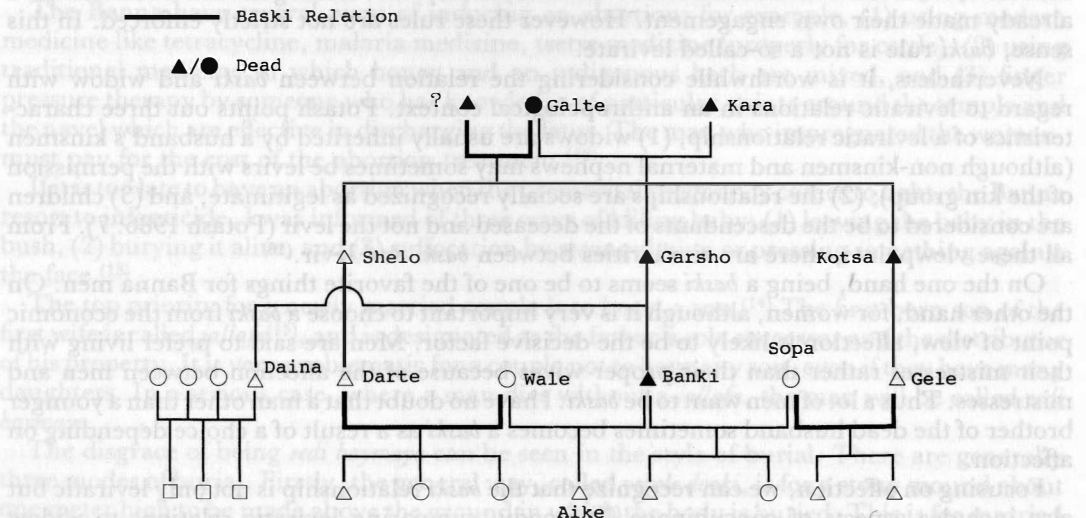

Fig. 1. Marital and *Baski* Relations in terms of Aike.

visitors, and have meals. Kraals are usually built next to the main house. Houses of co-wives, which are built at a certain distance from the main house but within the same compound, are much smaller than the main house and look somewhat simpler.

A unit of a wife and her biological children belong to the same house. After a husband's death, the family dissolves into units each consisting of a wife and her biological children living in the same house.

This feature, that a polygamous family is composed of several wife-children units, certainly applies to the Banna's case (Keesing 1975). Here is a situation in which the mother-children relationship must be based on biological connection. The Banna distinguish the biological mother (*inda*) from the co-mother (*ama*) when it is necessary to rigorously divide them by the criterion of biological connection. In daily life, however, the term *inda* is always extended not only to the biological mother but also to the co-mother, the mother's younger sisters and the father's younger brother's wife. Still, then again, a woman makes the distinction between her biological children (*naasi*) and her co-wives' children (*amanas*) when necessary to divide.

In the case shown in Figure 1, after Banki died, Wale took Darte as her *baski* and lived in a house built just outside Darte's compound with her children. She went to Darte's main house to join in daily chores as if she were one of his "real" wives.<sup>(24)</sup> Wale's unit (Wale and her children) became a component of Darte's household for the purpose of daily functions, although they were not completely absorbed into Darte's family.

The inheritance of cattle is an important issue for the Banna family and household. Banki's cattle were distributed through his eldest brother, and now most of them are under Aike's control in his kraal near his house. His younger brothers usually take care of the herd, but Darte's family is not involved in this matter. Rather Aike has a close relationship with Daina, who is Banki's biological brother, on the matter of cattle. They build cattle kraal together outside the village in the dry season. In other aspects such as morning coffee, hunting, and making periodical visits to the market in town. Aike keeps a connection with Daina and his sons. Thus we can conclude that Wale's unit strongly depends on Darte on the matter of cultivation, but Aike controls the herd with Daina. As a conclusion, Wale's unit is not functionally independent but strategically manages to select affiliative networks and switch them "on and off".

## 5. SECURING DESCENDANTS

### 5.1. Ghost Marriage and Related Tactics

Potash insists about the levirate that a functionalist explanation is inadequate because even though the widow remains in her husband's community and continues to bear children, this is the result of behavior (Potash 1986: 38). I agree with her about Wale's case. The functionalistic explanation, in a sense, might be an argument constructed after the result is known. However, there is no reason to deny the functionalism.

Evans-Pritchard mentions woman marriage and ghost marriage among the Nuer as ways of acquiring successors. Woman marriage and adoption are not carried out among the Banna. It is very popular to foster children of another family, but in this case, the children's clan is not changed.

Yet in Banna, ghost marriage (*dooki keemo*, marriage of the grave) is popular as a way of securing descendants as successors for a man's property and lineage.<sup>(25)</sup> I would like to briefly illustrate four cases below to demonstrate the particularity of ghost marriage among the Banna. As will be immediately seen, not all of these are may strictly be defined as ghost marriage in the common anthropological definition.

Case 1: Doobiar Kotsa recently died of meningitis. He was paying bridewealth when he died. His future wife still lives in Bashada. Although Doobiar had died, she is coming to his village in several years time and people say she will live with Doobiar's younger brother Orgo, who has finished his initiation. In this case, Orgo is considered to be her *baski*.

Case 2: Anno Teso died during the period of his bridewealth payment. He had paid four

cattle, two jerricans of alcohol (*katikala* or *arak*) and two calabash bottles of honey. His future wife will be coming to live with a man called Maile Garsho. Maile and Anno had the same clanship but the precise relationship between them is unclear. It is speculated that this *baski* relation was set up by relatives and that Anno's fiancée and Maile do not know each other. Anno's bridewealth is still being paid by his relatives.

Case 3: Bito Gemaro died of meningitis. His first wife, who bore him a daughter, had died years before. After she died he had arranged to be engaged with Soto Adeno, a woman of Shenko in Hamar, and had paid thirty goats, two cattle and two bottles of honey. Nobody knew who would be Soto's *baski* during my stay. Gele had needed to marry another woman to get his own *jallafa* because he had only a daughter when his first wife died. He must have expected that Soto would give birth to *jallafa* by another man.

The three cases above are not exactly ghost marriages because the principals were alive when they agreed to marry each respective woman. They died during the period of their bridewealth payment, which means they had already secured wives and successors.

In comparison, the next case would be understood as a ghost marriage in the typical sense.

Case 4: Wuka Shelo died when he was a *maz*, which is a transitional stage between the initiation ritual and engagement.<sup>(26)</sup> No sooner had he died than his parents managed to settle negotiations and carried out an engagement ritual where the bride fed sorghum with her own hand to the mouth of Wuka's corpse before burial. They say that ghost marriages permissible if the deceased man has completed initiation. Wuka's wife has born two children to date.

In another example, which is not an actual "case" but a sort of experiment, a native's answer to my extremely hypothetical question, "What happens if the chief dies before marriage?" was that if the chief (*bita*) were going to pass away at a young age, people would urge him to undergo the initiation ritual before his death.

I would like to point out that the minimum condition for a ghost marriage is that the husband has finished initiation before his death, and the engagement ritual must be carried out before interment. In a sense, the initiation ritual (*atsa*) is vital to establish his lineage.

I heard that an infertile man, called *eedi bu* meaning "infertile man" or "castrated man" (the term is related to *waaki bu*, a bullock) would likely kill himself. Since extra-marital sexual relationships, as noted above, are rigorously prohibited for a married woman, the *eedi bu* cannot allow another man to have sex with his wife so that she may bear his "social" child. Here arises a dilemma. They say that this dilemma can be solved by suicide; if the man dies, his wife will be free to have sex with her *baski* and can then bear her husband's legitimate child. Thus the deceased can avoid becoming *eedi haymaya*. However, I was unable to find any evidence of the suicide of *eedi bu*. Rather, a subtle way is found to bypass the problem.

Case 5: Bona married Kaala who was impotent. Kaala was so rigorous in his adherence to custom that he could not, even implicitly, allow his wife to have sexual relations, even if it was necessary for making his own descendants. Relatives struggled to persuade him to emigrate alone far away from his village. He finally agreed. The abandoned wife was liberated from him and bore four children. The second child's biological father is Bado. He was asked by her to have sex when Bado was a young boy who had not undergone initiation.

Thus the prohibition of extra-marital relationships may be flexibly negotiated with respect to the situation. Moreover, in this case, Bado was neither a married man nor even initiated. He was not *baski* but simply a temporary sex partner.

Strecker notes that in Hamar the extra-marital relationships of wives are tacitly permitted by husbands and effectively function to obtain "social" children for the husbands. "Gardu, married to an old, incapable man has herself had several lovers already and now Kula is her lover (and genitor of her youngest little son)" (Strecker 1980: 256). I also heard information suggesting the possibility of wives' adultery: "If a wife serves a meal in which medicine made



from a *kobe* tree (unidentified) is mixed, the husband will unconsciously forgive her infidelity”.

5.2. Paternity and Legitimacy

Gough (1971) identifies some patterns of paternity as in levirate and ghost marriage and woman marriage situation by introducing the concept of “legal marital partner” as distinct from the traditional pater/genitor distinction. Using these concepts, we are able to define *baski* as a child’s “genitor” (biological father) and “legal marital partner” of the child’s mother, and the deceased husband as “pater” (social father). For the Banna, it is not only the legal husband who can carry on legal marital relations: Gough identifies the criteria to distinguish a legal relation from an illegal one in terms of a man’s exclusive rights to a woman’s domestic service and sexuality (Gough 1971: 107). In the Banna example, the *baski* clearly meets Gough’s criteria as the legal marital partner.

Moreover it may be necessary to introduce “illegal marital partner” as a conceptual category in opposition to “legal marital partner”.<sup>(27)</sup> The typology in Table 1 combines two pairs of concepts: “legal/illegal marital partner” and “pater/genitor”. The most important part of the argument is that we can simultaneously consider both aspects of a man, as husband to his wife and as father to his child, and can then see the issue of legitimacy and the role of sexual (or reproductive) relationships in the same perspective. The six types in Table 1 illustrate which combinations of legitimatization and paternity are possible and which are not. The concept of legal marital partner for a widow could be divided into two vernacular terms, i.e. *geshoa* (legitimate husband)<sup>(28)</sup> and *baski*.

While types (1)a, (2)a and (2)b are possible, (1)b and (3) are impossible, the former because *baski* cannot be pater, the latter because illegal relationships (adultery etc.) cannot beget children who are considered legitimate. The possibility of type (4) depends on the situation. This is the case where the genitor for a child is an illegal marital partner to its mother. We are unable to assert that this kind of case is impossible because, as we have seen, there remains the possibility that an infertile husband tacitly may permit his wife to have sexual relations with another man to beget his social children. In this case, the man can become genitor of the children although this sexual relationship is technically illegal.

6. CONCLUSION: TOWARD A WIDER PERSPECTIVE

Aike’s case (see Figure 1) may require an additional explanation, because Aike introduces Darte as “my father” (*imba*) and the villagers also regard all Wale’s children (including Aike) as Darte’s children, although Darte is not even Aike’s genitor. This case suggests that a man

Table 1. Possibility and impossibility of being a “father”

		Partner of marital relationship in terms of "mother"		
		Legal relationship		Illegal relationship
		<i>geshoa</i>	<i>baski</i>	
"Father" in terms of "child"	pater	(1) a possible	(1) b impossible	(3) impossible
	genitor	(2) a possible	(2) b possible	(4) ideally impossible but actually possible

who is neither genitor nor pater can be recognized as "father" if he is only a "legal marital partner" (*baski* in the Banna case) of the children's biological mother. It should be noted that the term *imba* can be used more flexibly in practice than its descriptive connotation as a kinship term. "Pater", as used in traditional anthropological writing must be divided into two aspects of fatherhood: one who legitimizes a child based upon prescription and one who is *de facto* recognized as the father by himself and those around him in accordance with the situation of everyday life and his own father-like behavior.

We can conclude that "*imba*" has connotations of genitor and two kinds of pater, and is always identified through the biological mother of the child. This kind of biological connection between mother and child relates to Evans-Pritchard's thesis of the "matrilineal aspect among an agnatic society", and coincides with the fact that a mother-children unit comprises the core of the structure of a polygamous family.

Factors, which define paternity, are complex and circumstantial. Although the analysis in this article is admittedly lacking in sophistication, the framework may be useful in thinking about reproductive technology and the continuing challenges to the family. New reproductive technology, that manipulates a sperm and an ovum rather than a father and a mother, requires us to consider parent-child relations at a deeper level of indigenous knowledge, that is, ethnobiology. Moreover, further work is needed on the broadly social connotation of fatherhood and motherhood. However, such themes are beyond the scope of the present paper.

### ACKNOWLEDGEMENTS

I stayed in Ethiopia from February 1993 to May 1994, and March to September 1998, with research permission from the Institute of Ethiopian Studies. I am indebted to Dr. Taddese Beyene, Professor Bahru Zewde and Dr. Abdussamad Ahmad as directors of IES. My research was supported by a grant from the projects "Comparative studies on Agricultural and Pastoral Societies in Northeast Africa" (1993-4) and "Comparative Studies on Indigenous Knowledge on the Environment in Ethiopian Societies" (1998) (project leader: Katsuyoshi Fukui of Kyoto University). These projects were funded by a Grant-in-Aid for Scientific Research from the Japanese Ministry of Education, Science, Sport and Culture. I am also indebted to Professor Katsuyoshi Fukui and other members of the project.

I wish to thank all the Ethiopians who gave me great help and hospitality. Regrettably I cannot mention all of them by name. However, I cannot omit the followings: Dr. Merid Aregey, Mr. Gebre Yintiso, Mr. Mellese Getu, Mr. Fikremarkos Desta, Mr. Kassate Berhane Mengiste, Ms. Haregewoin Kebede, and Danya Belachew who helped me as a Banna student during my first fieldwork period, and then as chief of the Hamar-Banna Wereda office. Dr. Jean Lydall generously showed me her unpublished paper on Hamar history and gave me useful suggestions.

I am very grateful to Mr. Carl Harvey who kindly read the draft of this paper, polished my English and gave me useful suggestions.

"Marriage and sexuality" is a very delicate theme since it inevitably intrudes on people's privacy. In a study like the present one, we should, as much as possible, be careful to keep a delicate balance between the researcher and the people studied. I was unable to collect complete information about this matter because of its delicacy. For the same reason, I have changed the names of all the people mentioned in this paper.

### NOTES

- (1) Matsuzono (1987) defines the Nuer conception of kinship as 'ovum-istic', the Okinawan conception as 'sperm-istic'. Although she does not use these terms, Gough (1971: 111) makes the same point comparing the Nuer and the Brahman caste of India.
- (2) This article is a revised and up-dated version of a report originally published in Japanese in 1996 (Masuda 1996). The Banna are agro-pastoral people living in woodland-savannah of an altitude of 1,500 m between the Omo River and the Woito River in Southern Ethiopia. Their population seems to be about forty thousand. They speak Banna, an Omotic language. I conducted my fieldwork in Bori village, which is located at the geographical center of Banna land. In this paper I refer to this village when I use the simple term "the village."

- (3) Only the Galabu moiety has the custom of circumcision.
- (4) Unfortunately, I could not obtain information about this ritual. Some said the ritual involves scooping water or sand from the river. Further, the Banna women do not have so-called female circumcision. I briefly discussed *gudul* in my master's thesis (Masuda 1995).
- (5) This is a simplified explanation about clans and moieties.
- (6) This word (*eda*) is derived from *eedi* which means general human being, and this unmarriageable category is also called *mete kala* which literally means "one clan" or "same clan".
- (7) Banna society is polygamous. The residence list of Bori village, in which I noted all residences' name, sex and estimated age, shows that there were 50 married men and 117 married women in 1994. Out of 50 men, 29 men had over one wife, and the oldest man had 11 wives. On average a man had 2.3 wives in the village.
- (8) See next section.
- (9) Lydall and Strecker note that premarital pregnancy is punishable (Lydall and Strecker 1979: 153).
- (10) The word *duba* originally means ground of accumulated cow dung in a cattle enclosure. This is where unmarried people are buried.
- (11) A traveler, C. H. Stigant, who visited Karo on the Omo river in the 1900s, noted, "All these three tribes (Karo, Banna and Bashada) are in the habit of strangling their first born children, and throwing the baby away. The Kerre (Karo) throw it into the river, where it is eaten by crocodiles, and the other two leave it in the bush for hyenas to eat... They also declared that it was only illegitimate children who were treated in this way" (Stigant 1969: 234-235).
- (12) It is certain that abortion and infanticide are still carried out. I know of a man who has the skill to perform an abortion, but I refrained from interviewing him on the subject. According to some information from several informants, this skill is not hereditary.
- (13) There was another infanticide case among the Gata clan which involved the chiefs' lineage. The custom named *gat* is the killing of the first baby of the first wife if the baby is male. I am not sure if Banna are still following the tradition. The present chief of Eastern Banna, Adeno Garsho, said to me that they now have an alternative practice in which they smother a sheep by stuffing butter into its mouth and nostrils, by which the first-born baby is symbolically killed and physically remains alive.
- (14) How many children does a Banna woman bear in her life? It may be presumed that one woman can give birth to a maximum of eight children since Bori village records shows that one woman bore eight children and eight women bore seven children. Moreover, we may assume that Banna women reach the age limit for bearing children around the age of 44 on the assumption that women give birth once every three years after bearing her first child at 20 years old. Women who were likely over 44 years old had an average of 5.3 children.
- (15) Another term, *toidi*, has the same meaning, but *jallafa* is more popular.
- (16) It is said that some widows like to sleep with anybody who wants to have sex with them. These widows are called *maa budana*, and many boys visit them.
- (17) The category of younger brother (*kana*) of the deceased husband extends to sons of his father's younger brother. Likewise, While *imba* is applied to "father" and "father's younger brother", "father's older brother" is categorized as *eike* which is also used to mean "father's father".
- (18) I do not use the term "leviratic marriage" in considering the *baski* relationship, because a child born to a *baski*'s partner belongs to her deceased husband, and a *baski* does not pay any bridewealth to enter into relations with a widow.
- (19) In Hamar a widow who makes a *baski* relationship is called *baski* or *noko-ma* (*noko* means water) which is translated as "mistress" by Strecker (1980: 226). I have not heard this word during my own research.
- (20) Moreover Aike considers Daina, who is Banki's younger brother, to be his *imba* and actually calls him *imbo*, which is a term of address to a father. Daina is classified as a father in Banna kinship terminology.
- (21) I think that using the "full name" is not a very old custom. On the registration card for the national election in 1994, each adult man's name was registered with his father's name and father's father's name.
- (22) When I visited the village again in 1998, the situation around this household changed. Darte had

- converted to Christianity, along with Wale's family unit. Since Christianity does not take a favorable view of polygamy, he has only Wale as his Christian wife.
- (23) Banna society has no custom of private land ownership. Each person is given permission to use land by elders in the village.
- (24) It must be noted that the *baski* relationship between Wale and Darte began before Darte married his second wife.
- (25) In my previous paper in Japanese (Masuda 1996) I stated that I had not found any evidence of ghost marriage. However, I found several cases of ghost marriage when I stayed in the village in 1998.
- (26) The status of being *maz* is unstable. See Strecker's analysis (Strecker 1988: 151-2, 210).
- (27) When I use the term "legal", I refer to relations accepted by other people as based on Banna tradition and custom, because the Banna have no written law. In this local sense the custom of *baski* is undoubtedly legal.
- (28) Here I use the word *geshoa* only in its strict sense of a legal husband. In fact the word has a wider application; for example, Banna address as *geshoa* almost every adult man who is older than themselves.

## REFERENCES

- Barnes, J. A.  
1973 Genetrix: Genitor:: Nature: Culture?. In Jack Goody (ed.), *The Character of Kinship*. Cambridge University Press, pp. 61-73.
- Evans-Pritchard, E. E.  
1951 *Kinship and Marriage among the Nuer*. Clarendon Press.
- Goody, J.  
1976 *Production and Reproduction: Comparative Study of the Domestic Domain*. Cambridge U. P.
- Gough, K.  
1971 Nuer Kinship: Re-examination. In Beidelman (ed.), *The Translation of Culture: Essays to E. E. Evans-Pritchard*. Tavistock Publications.
- Hutchinson, S.  
1980 Relations Between the Sexes among the Nuer: 1930. *Africa* 50(4): 371-388.
- Jensen, Ad. E.  
1959 Die Banna. In Jensen (ed.), *Altvölker Süd-Äthiopiens*, W. Kohlhammer Verlag. pp. 313-336
- Keesing, R.  
1975 *Kin Groups and Social Structure*. Holt, Rinehart and Winston.
- Lydall, J.  
1994 Beating around the Bush. In Bahru Zewde, R. Pankhurst and Taddese Beyene (eds.), *Proceedings of the Eleventh International Conference of Ethiopian Studies*, Addis Ababa, April 1-6 1991, Institute of Ethiopian Studies, Addis Ababa University. pp. 205-225
- Lydall, J. & I. Strecker.  
1979 *The Hamar of Southern Ethiopia vol. 2: Baldambe Explains*. Klaus Renner Verlag.
- Masuda, K.  
1995 *Buzoku shakai ni okeru chifu to kurasu kan'nen: Echiopia nanbu Omo kei noubokumin Banna no Bita ni kansuru houkoku (Chiefs and Class Identity in a Tribal Society: A Report on "bita" among the Banna of Southern Ethiopia)*. MA Thesis presented to Tokyo Metropolitan University (In Japanese).  
1996 Echiopia nanbu Banna ni okeru sei to kekkon: Fusei to chakushutsusei wo meguru jinruigakuteki dessan (Sexuality and Marriage among the Banna of southern Ethiopia: An Anthropological Sketch about Legitimacy and Paternity). In *Shakai Jinruigaku Nenpo* (Annual Report of Social Anthropology) 22: 171-186, Kobundo. (In Japanese)
- Matsuzono, M.  
1987 Fukei shutsuji shudan ni okeru shison kakutoku ni tsuite (On strategies to obtain descendants in paternal societies). In *Tokyo Toritsu Daigaku Jinbun Gakuhou* No. 194: 1-15. (In Japanese)
- Potash, B.  
1986 Widows in Africa: An Introduction. In B. Potash (ed.), *Widows in African Societies*. Stanford U. P. pp. 1-43
- Stigant, C. H.  
1969 (1910) *To Abyssinia through an unknown land*. Negro U. P.
- Strathern, M.

- 1992 *Reproducing the Future: Essays on Anthropology, Kinship and the New Reproductive Technologies*. Manchester University Press.
- Strecker, I.  
 1980 *The Hamar of Southern Ethiopia vol. 3: Conversations in Dambaiti*. Klaus Renner Verlag.  
 1988 *The Social Practice of Symbolization: An Anthropological Analysis*. The Athlone Press.

## Mitochondrial Variation in Grivet Monkeys (*Cercopithecus aethiops aethiops*)

MAEOTO K. SHIMADA

Acad. University

Grivet monkey populations in central Ethiopia shared a homogeneous distribution of nuclear variations but differentiated distribution in mtDNA. To explain this difference in gene distribution patterns, I examined the effect of male migration on homogenized nuclear variations among populations. If migration involving mtDNA differentiations occurred in both sexes, male migration is assumed to have homogenized nuclear gene distribution after isolation, because of female philopatry. Under this assumption, the flow required for homogenization is obtained by computer simulation using a migration rate calculated from distribution of nuclear variations under the two-dimensional stepping stone model. The computer simulation indicates that as little 10<sup>5</sup> years is enough to homogenize nuclear variation via male migration.

**Key words:** *Cercopithecus aethiops aethiops*, nuclear genome, mtDNA, simulation, Central Ethiopia.

### 1. INTRODUCTION

1.1 Previous studies concerning the relationship between nuclear and mitochondrial DNA variations

Wild populations of various vertebrate species have been studied using nuclear DNA and mitochondrial DNA (mtDNA) markers. Some of these studies have produced different pictures regarding allozyme (variation of nuclear coded protein) and mtDNA results (e.g., Barb & Avise 1995). That is, they have shown a spatially homogeneous distribution of allozyme variation, and a heterogeneous distribution of mtDNA variation. The differences observed in cercopithecoid primates are considered to be due to a sex specific migration pattern (Melnik & Hodges 1991, 1993, 1995). Males of most cercopith-like species leave their natal social group and serve as stragglers, whereas females remain in their natal groups throughout life (Pruvy & Parker 1987). This female philopatry restricts the gene flow of mtDNA. Because male mtDNA is not inherited to next generation, male migration was considered to be a factor both regarding the distribution of allozyme variation but not mtDNA variation. However, only a few empirical studies have looked at the same wild populations using both allozyme and mtDNA.